

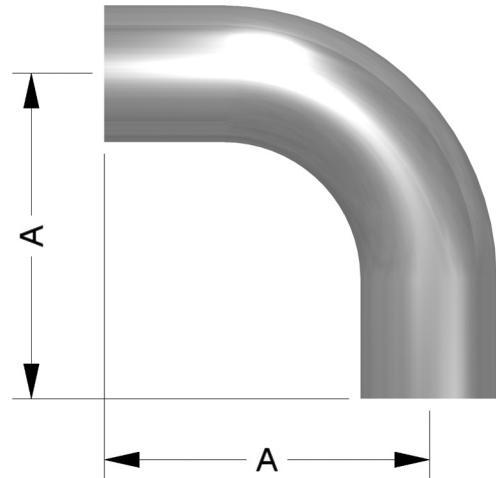

90° Weld Ell | B2S-Size-AL6XN-Finish

"-7" Finish Part Number	Size (Tube OD)	Length (A)
B2S-0.5-AL6XN-7	1/2"	3.000
B2S-0.75-AL6XN-7	3/4"	3.000
B2S-1-AL6XN-7	1"	3.000
B2S-1.5-AL6XN-7	1-1/2"	3.750
B2S-2-AL6XN-7	2"	4.750
B2S-2.5-AL6XN-7	2-1/2"	5.500
B2S-3-AL6XN-7	3"	6.250
B2S-4-AL6XN-7	4"	8.000

Dimension "A" meets requirements per ASME BPE table DT-7.



45° Weld Ell | B2KS-Size-AL6XN-Finish

"-7" Finish Part Number	Size (Tube OD)	Length (A)
B2KS-0.5-AL6XN-7	1/2"	2.250
B2KS-0.75-AL6XN-7	3/4"	2.250
B2KS-1-AL6XN-7	1"	2.250
B2KS-1.5-AL6XN-7	1-1/2"	2.500
B2KS-2-AL6XN-7	2"	3.000
B2KS-2.5-AL6XN-7	2-1/2"	3.375
B2KS-3-AL6XN-7	3"	3.625
B2KS-4-AL6XN-7	4"	4.500

Dimension "A" meets requirements per ASME BPE table DT-8.

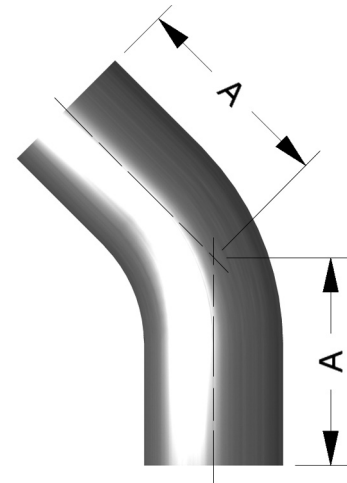

45° TriClamp Ell | B2KMP-Size-AL6XN-Finish

"-7" Finish Part Number	Size (Tube OD)	Length (A)
B2KMP-0.5-AL6XN-7	1/2"	1.000
B2KMP-0.75-AL6XN-7	3/4"	1.000
B2KMP-1-AL6XN-7	1"	1.125
B2KMP-1.5-AL6XN-7	1-1/2"	1.438
B2KMP-2-AL6XN-7	2"	1.750
B2KMP-2.5-AL6XN-7	2-1/2"	2.063
B2KMP-3-AL6XN-7	3"	2.375
B2KMP-4-AL6XN-7	4"	3.125

Dimension "A" meets requirements per ASME BPE table DT-17.

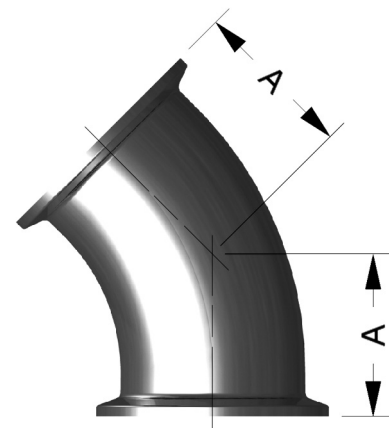



90° TriClamp Ell | B2CMP-Size-AL6XN-Finish

"-7" Finish Part Number	Size (Tube OD)	Length (A)
B2CMP-0.5-AL6XN-7	1/2"	1.625
B2CMP-0.75-AL6XN-7	3/4"	1.625
B2CMP-1-AL6XN-7	1"	2.000
B2CMP-1.5-AL6XN-7	1-1/2"	2.750
B2CMP-2-AL6XN-7	2"	3.500
B2CMP-2.5-AL6XN-7	2-1/2"	4.250
B2CMP-3-AL6XN-7	3"	5.000
B2CMP-4-AL6XN-7	4"	6.625

Dimension "A" meets requirements per ASME BPE table DT-16.

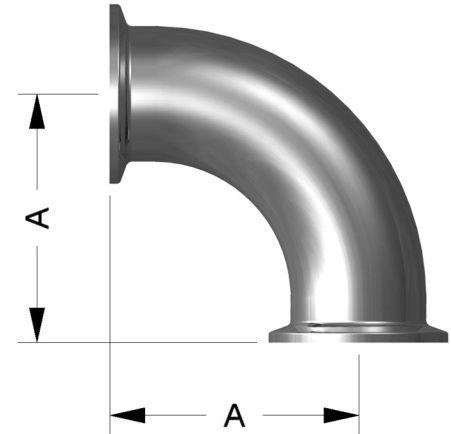

90° TriClamp X Weld Ell | B2CMW-Size-AL6XN-Finish

"-7" Finish Part Number	Size (Tube OD)	Length (A)	(B)
B2CMW-0.5-AL6XN-7	1/2"	3.000	1.625
B2CMW-0.75-AL6XN-7	3/4"	3.000	1.625
B2CMW-1-AL6XN-7	1"	3.000	2.000
B2CMW-1.5-AL6XN-7	1-1/2"	3.750	2.750
B2CMW-2-AL6XN-7	2"	4.750	3.500
B2CMW-2.5-AL6XN-7	2-1/2"	5.500	4.250
B2CMW-3-AL6XN-7	3"	6.250	5.000
B2CMW-4-AL6XN-7	4"	8.000	6.625

Dimensions "A" and "B" meet requirements per ASME BPE table DT-12.

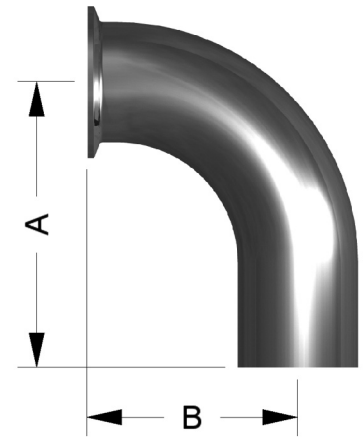

45° TriClamp X Weld Ell | B2KMW-Size-AL6XN-Finish

"-7" Finish Part Number	Size (Tube OD)	Length (A)	(B)
B2KMW-0.5-AL6XN-7	1/2"	2.250	1.000
B2KMW-0.75-AL6XN-7	3/4"	2.250	1.000
B2KMW-1-AL6XN-7	1"	2.250	1.125
B2KMW-1.5-AL6XN-7	1-1/2"	2.250	1.438
B2KMW-2-AL6XN-7	2"	3.000	1.750
B2KMW-2.5-AL6XN-7	2-1/2"	3.375	2.063
B2KMW-3-AL6XN-7	3"	3.625	2.375
B2KMW-4-AL6XN-7	4"	4.500	3.125

Dimensions "A" and "B" meet requirements per ASME BPE table DT-13.

