

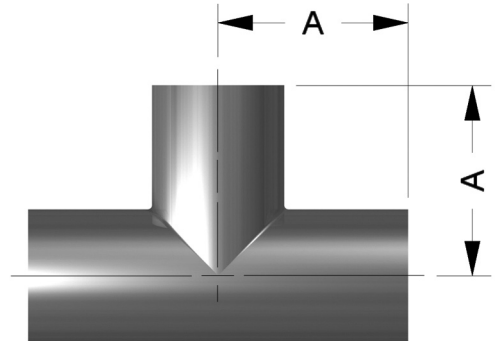

Weld Tee | B7WWW-Size-AL6XN-Finish

"-7" Finish Part Number	Size (Tube OD)	Length (A)
B7WWW-0.5-AL6XN-7	1/2"	1.875
B7WWW-0.75-AL6XN-7	3/4"	2.000
B7WWW-1-AL6XN-7	1"	2.125
B7WWW-1.5-AL6XN-7	1-1/2"	2.375
B7WWW-2-AL6XN-7	2"	2.875
B7WWW-2.5-AL6XN-7	2-1/2"	3.125
B7WWW-3-AL6XN-7	3"	3.375
B7WWW-4-AL6XN-7	4"	4.125

Dimension "A" meets requirements per ASME BPE table DT-9.



Short Outlet Tee | B7WWMS-Size-AL6XN-Finish

"-7" Finish Part Number	Size (Tube OD)	Length (A)	(B)
B7WWMS-0.5-AL6XN-7	1/2"	1.875	1.000
B7WWMS-0.75-AL6XN-7	3/4"	2.000	1.125
B7WWMS-1-AL6XN-7	1"	2.125	1.125
B7WWMS-1.5-AL6XN-7	1-1/2"	2.375	1.375
B7WWMS-2-AL6XN-7	2"	2.875	1.625
B7WWMS-2.5-AL6XN-7	2-1/2"	3.125	1.875
B7WWMS-3-AL6XN-7	3"	3.375	2.125
B7WWMS-4-AL6XN-7	4"	4.125	2.750

Dimensions "A" and "B" meet requirements per ASME BPE table DT-15.

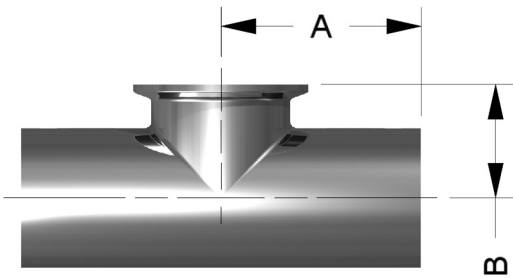



Reducing Weld Tee | B7RWWW-Size-AL6XN-Finish

"-7" Finish Part Number	Size (Tube OD)	Length (A)	(B)
B7RWWW-0.75X0.5-AL6XN-7	3/4" x 1/2"	2.000	2.000
B7RWWW-1X0.5-AL6XN-7	1" x 1/2"	2.125	2.125
B7RWWW-1X0.75-AL6XN-7	1" x 3/4"	2.125	2.125
B7RWWW-1.5X0.5-AL6XN-7	1-1/2" x 1/2"	2.375	2.375
B7RWWW-1.5X0.75-AL6XN-7	1-1/2" x 3/4"	2.375	2.375
B7RWWW-1.5X1-AL6XN-7	1-1/2" x 1"	2.375	2.375
B7RWWW-2X0.5-AL6XN-7	2" x 1/2"	2.875	2.625
B7RWWW-2X0.75-AL6XN-7	2" x 3/4"	2.875	2.625
B7RWWW-2X1-AL6XN-7	2" x 1"	2.875	2.625
B7RWWW-2X1.5-AL6XN-7	2" x 1-1/2"	2.875	2.625
B7RWWW-2.5X1-AL6XN-7	2-1/2" x 1"	3.125	2.875
B7RWWW-2.5X1.5-AL6XN-7	2-1/2" x 1-1/2"	3.125	2.875
B7RWWW-2.5X2-AL6XN-7	2-1/2" x 2"	3.125	2.875
B7RWWW-3X0.5-AL6XN-7	3" x 1/2"	3.375	3.125
B7RWWW-3X0.75-AL6XN-7	3" x 3/4"	3.375	3.125
B7RWWW-3X1-AL6XN-7	3" x 1"	3.375	3.125
B7RWWW-3X1.5-AL6XN-7	3" x 1-1/2"	3.375	3.125
B7RWWW-3X2-AL6XN-7	3" x 2"	3.375	3.125
B7RWWW-3X2.5-AL6XN-7	3" x 2-1/2"	3.375	3.125
B7RWWW-4X1-AL6XN-7	4" x 1"	4.125	3.625
B7RWWW-4X1.5-AL6XN-7	4" x 1-1/2"	4.125	3.625
B7RWWW-4X2-AL6XN-7	4" x 2"	4.125	3.875
B7RWWW-4X3-AL6XN-7	4" x 3"	4.125	3.875

Dimensions "A" and "B" meet requirements per ASME BPE table DT-10.

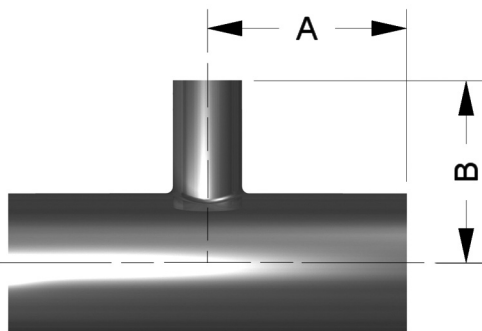



Short Outlet Reducing Tee | B7RWWMS-Size-AL6XN-Finish

"-7" Finish Part Number	Size (Tube OD)	Length (A)	(B)
B7RWWMS-0.75X0.5-AL6XN-7	3/4" x 1/2"	2.000	1.000
B7RWWMS-1X0.5-AL6XN-7	1" x 1/2"	2.125	1.125
B7RWWMS-1X0.75-AL6XN-7	1" x 3/4"	2.125	1.125
B7RWWMS-1.5X0.5-AL6XN-7	1-1/2" x 1/2"	2.375	1.375
B7RWWMS-1.5X0.75-AL6XN-7	1-1/2" x 3/4"	2.375	1.375
B7RWWMS-1.5X1-AL6XN-7	1-1/2" x 1"	2.375	1.375
B7RWWMS-2X0.5-AL6XN-7	2" x 1/2"	2.875	1.625
B7RWWMS-2X0.75-AL6XN-7	2" x 3/4"	2.875	1.625
B7RWWMS-2X1-AL6XN-7	2" x 1"	2.875	1.625
B7RWWMS-2X1.5-AL6XN-7	2" x 1-1/2"	2.875	1.625
B7RWWMS-2.5X1-AL6XN-7	2-1/2" x 1"	3.125	1.875
B7RWWMS-2.5X1.5-AL6XN-7	2-1/2" x 1-1/2"	3.125	1.875
B7RWWMS-2.5X2-AL6XN-7	2-1/2" x 2"	3.125	1.875
B7RWWMS-3X0.5-AL6XN-7	3" x 1/2"	3.375	2.125
B7RWWMS-3X0.75-AL6XN-7	3" x 3/4"	3.375	2.125
B7RWWMS-3X1-AL6XN-7	3" x 1"	3.375	2.125
B7RWWMS-3X1.5-AL6XN-7	3" x 1-1/2"	3.375	2.125
B7RWWMS-3X2-AL6XN-7	3" x 2"	3.375	2.125
B7RWWMS-4X0.5-AL6XN-7	4" x 1/2"	4.125	2.625
B7RWWMS-4X0.75-AL6XN-7	4" x 3/4"	4.125	2.625
B7RWWMS-4X1-AL6XN-7	4" x 1"	4.125	2.625
B7RWWMS-4X1.5-AL6XN-7	4" x 1-1/2"	4.125	2.625
B7RWWMS-4X2-AL6XN-7	4" x 2"	4.125	2.625
B7RWWMS-4X2.5-AL6XN-7	4" x 2-1/2"	4.125	2.625
B7RWWMS-4X3-AL6XN-7	4" x 3"	4.125	2.625

Dimensions "A" and "B" meet requirements per ASME BPE table DT-14.

